

- PEG -

Switching power supply SP-R

Operating instructions



2015

Contents

SAFETY INSTRUCTIONS	2
SPECIAL SYMBOLS.....	2
SAFETY INSTRUCTION AND COMMANDS	2
INTRODUCTION	3
DESCRIPTION	4
TYPE CODE.....	4
PARAMETERS	6
INSTALLATION	7
MECHANICAL MOUNTING.....	7
ELECTRICAL WIRING	7
BATTERY CONNECTION	9
SETTINGS	10
OPERATION	11
OPERATION STATES SIGNALING.....	11
LCD DISPLAY FUNCTION.....	11
ERROR SUMMARY	16
MAINTENANCE	18
SERVICE AND SERVICE ASSISTANCE	19
GUARANTEE TERMS	20

Safety Instructions

Special symbols



Touching the electrical equipment may be fatal



Warning, read operating instructions



Warning, battery



Do not disposed together with domestic waste

Safety instruction and commands



1. Only authorized and informed person can work on this device
2. Earth the device properly
3. Disconnect all wiring before any manipulation
4. Do not unplug any connector under voltage

Introduction

Switching chargers of the SP-R series are intended for charging station batteries of nominal voltage 110V and 220V.

Chargers are suitable for supplying DC circuits with combination of charging station batteries. Switching chargers of the SP-R series fully comply with the requirements of the station battery charging standard EUROBAT.

Power supply unit offers function of temperature compensation of charging voltage, output wiring resistance measurement or fast charging. Different charging characteristics can be used- IU₀, IUU₀ etc.

Description

The power unit is fit into 3U 19" rack and is designed for built-in mount into switchgears. All connection and signaling points are situated in front panel.

Compact construction of the charger brings all advantage of switching units in comparison with standard power supply unites equipped with transformer – primarily lower weight and smaller dimensions. Advanced software equipment leads to higher user comfort and to the merging different measure devices into one device.

Nominal output current is 50A for voltage 110V DC and 25A for voltage 220V DC. In case of need up to 16 power units can be set together in parallel operation mode, with possibility of changeover of wrong module during operation without blackout. Output voltage fuses are placed in rear panel.

The power unit has force cooling which is controlled according to momentary temperature of the cooler. This solution increases lifetime of ventilator and contributes to low-noise run of the unit.

Regulation is controlled by processor card ProDrive III equipped with DSP processor Texas Instruments.

Processor control with combination of power electronics elements temperature measurement allows short-term operation by reducing output current as well during deterioration of temperature conditions.

The unit can be equipped by 3" HMI colour LCD panel. The HMI panel can be fit in switchboard as well.

Type code

-PEG- xx/xx SP-R

nominal voltage	
nominal current	
switching charger	

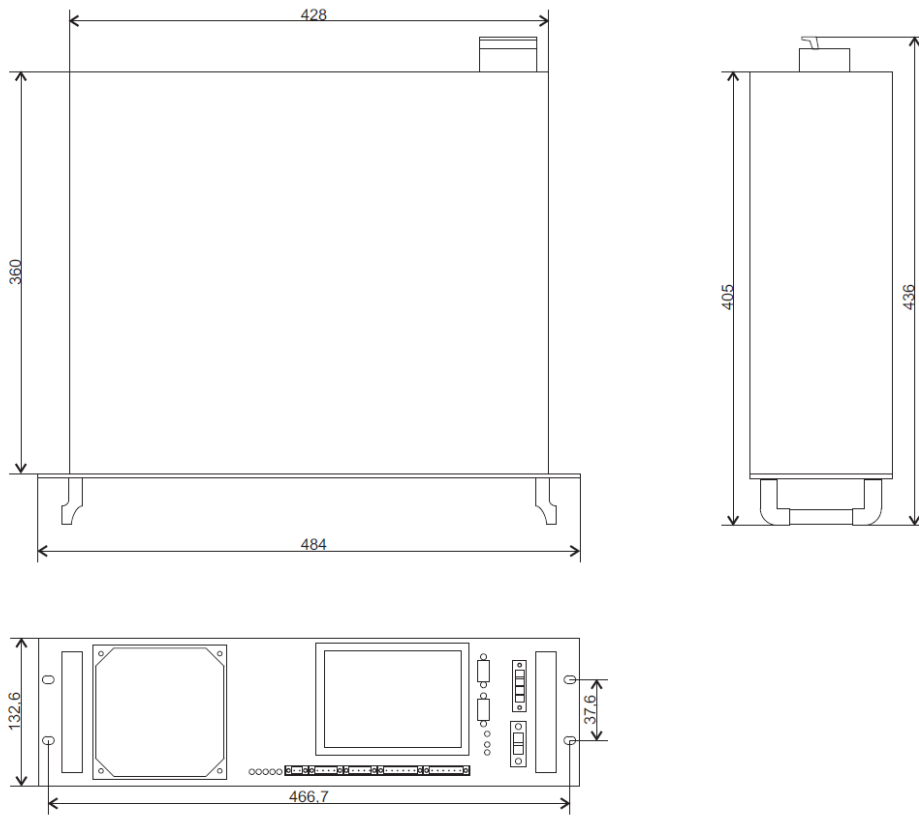

Picture 1 Dimensions SP-R with LCD panel

Parameters

Basic types		
U_{in}	3x 400/230 V	
I_{in}	16A	
f_{in}	30-70 Hz	
U_n	110 V DC	220 V DC
I_{max}	50A	25A
Current ripple	<3%	
Efficiency	92 - 95%	
Power factor	0,98	
Parallel operation	YES	
Short circuit protection	YES	
LCD	YES	
Temperature compensation	YES	
Fast charging	YES	
Communication	RS232, RS485	
Logical inputs	2	
Analog inputs	1	
Logical outputs	9 (230 V AC/5 A)	
Operational temperature	-25 to +40 °C	
Dimension	360 x 484 x 133 mm	
Weight	25 kg	
Protection	IP 20	
Options		
PT100/PT1000		
3,5" HMI		
Load current measurement		

Table 1 Parameters

Installation

Mechanical mounting

The power unit is fit into 3U 19`` rack and is designed for built-in mount into switchgears. The unit is necessary to mount into factory made support panel or into corresponding device. The unit is fixed by four screw-bolts M6 going throw front panel (picture 2). Mounting dimensions including mounting holes dimension are shown on picture 1.

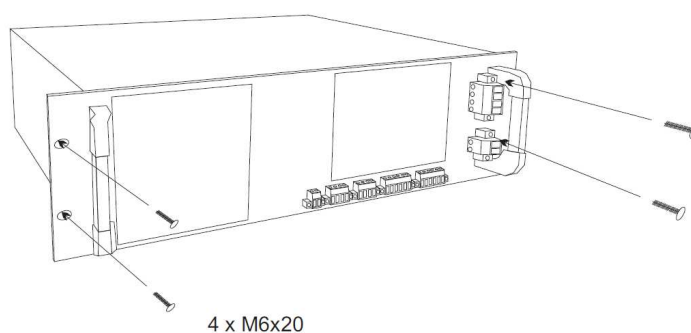

Picture 2 Mounting

The unit has to be mounted only in horizontal position. Sufficient room for inflow and outlet of cooling air is necessary – 50mm in front of unit, 100mm at back of unit. The surrounding temperature must be in range from -25°C to +40°C, otherwise right function can not be warrant.

Electrical wiring



All connection and signaling points are situated in front panel.

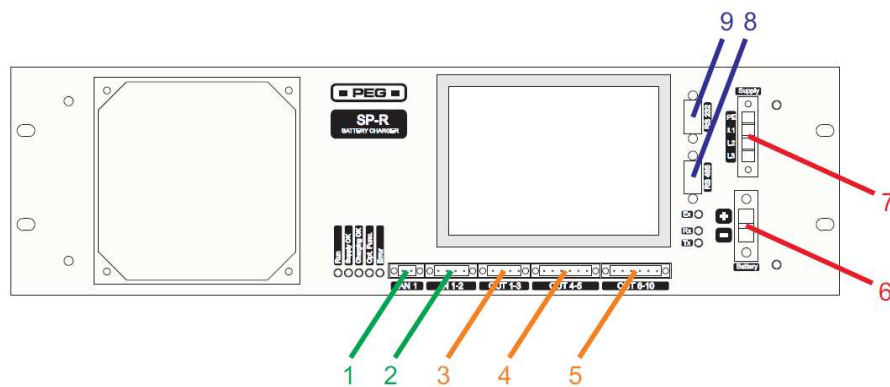

Picture 3 Connectors

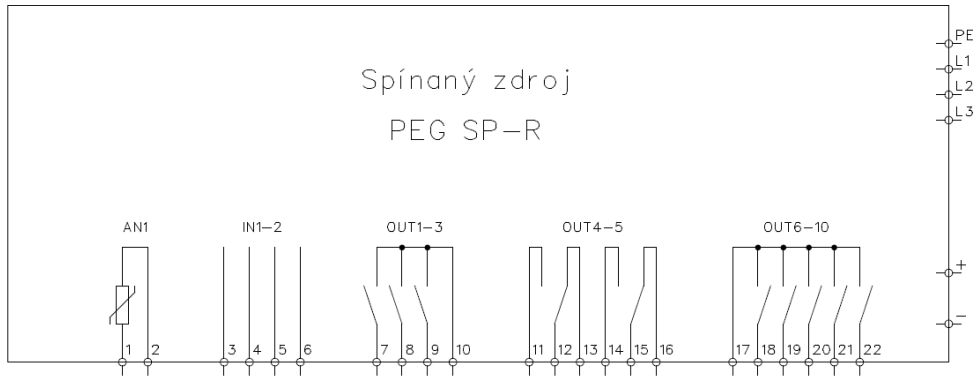

Picture 4 Connector wiring

	Function	Voltage
Connector 1	PT100/PT1000	
Connector 2	2 digital inputs	internal 24 V DC or external 110/220 V DC (set by manufacturer)
Connector 3	3 logical outputs; relay with common pin	230 V AC / 5 A 48 V DC / 5A
Connector 4	2 logical outputs; relay with common pin	230 V AC / 5 A 48 V DC / 5A
	external display supply	24 V DC (set by manufacturer)
Connector 5	5 logical outputs; relay with common pin	230 V AC / 5 A 48 V DC / 5A
Connector 6	Battery output	110 V/220 V DC (set by unit type)
Connector 7	Supply voltage	3x400/220V AC + PE
Connector 8	Communication port RS 485	
Connector 9	Communication port RS 232	

Table 2 Connectors

In case of external HMI panel mounting is necessary to connect port RS232 with the charger and provide power supply 24V DC for HMI panel. For the power supply connector 4 (OUT 5) can be used, terminals 14 (+) and 16 (-). This possibility has to be set by manufacturer.



The isolation of the wires plugged into connectors dispatch remove only in needed length, touchable bare wiring is not allowable

Screw-terminals of connectors 1-5 are to be tightening by torque 0,5Nm, connector 6 by torque 1,5Nm and connector 7 by torque 2Nm.



Earth wire on terminal PE in connector 7 must be plug-in properly.

Battery connection



The inputs wiring resistance can be measured before battery plug-in. For this measurement, battery supply wiring is unplugged on battery, the wiring is connected (charger far end) and the charger provide resistance measurement. The measurement is release by switching input IN2 (function "Start of resistance measurement"). Charger works with the result of measurement and the output voltage is adjusted which means, charger compensate resistance of supply wiring.

After measurement the battery can be plug-in, it is necessary to observe the procedure recommended by producer of batteries.



The function for wiring resistance measurement is optional, not all chargers can provide it. Before application of this function consult the possibility with manufacturer.



Observe the right battery polarity!

Only battery with nominal voltage the same as nominal output voltage of charger can be connected.

Settings

Inputs and outputs are programmable which means adjustment of the power unit to concrete application. For each input and output one or up to all switching possibilities can be set (see table 3). Voltage and current of individual inputs and outputs are mentioned in chapter "Installation", table 2.

Each input and output can be logically inverted.

IN	External failure	Charger shutdown	
	Fast charging start		
	Resistance measurement start		
	ON/OFF		
	Siren silence		
OUT	Charger failure	Power supply loss	Unit supplied from DC
		Over voltage	Unit supplied from DC
		Under voltage	Unit supplied from DC
		Fusses	
		Summary fault	
		Over current	
	Battery diagnostics	Battery over voltage	Charger shutdown
		Battery not charged	
		30% capacity left	
		10% capacity left	
		Battery discharged	Battery unfasten
		Charging with higher voltage	
		Charging with lower voltage	
		Run	
		Siren	

Table 3 Inputs and outputs

Operation

Operation states signaling

The unit can be equipped with HMI LCD panel which is used for settings and for signaling of operation states or fault reports.

All units are equipped with set of LEDs for signalling of basic operation states.

LEDs	Meaning
RUN	Operation, without faults
Supply OK	Power supply 400V is present
Charging OK	Charging voltage in tolerance
Opt. Func.	Optional function is active
Error	Unit failure or fault

LCD display function

LED signaling is active as well in units with LCD panel. The panel can be mounted in switchgear or on other places far from charger rack (central control board etc.).

There are five basic schemes available on the HMI display; buttons on panel screen bottom are used for changes.



The panel is controlled by touching on selected point, is strictly forbidden to use objects which could damage the screen (sharp object, screw-driver etc.).

Overview

Basic screen for fast diagnostics. Text description is shown as well as measured value of charger, battery and output voltage.

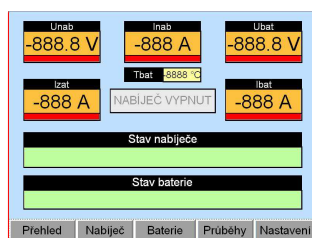

Komentář [PN1]:

Charger

Screen serves detailed information about charger inner electrical values, temperatures of components and about actual status of all inputs and outputs.

The list of error-states could be invoked from the screen by pressing button "Errors".

Error history is available from the screen by pressing "History on", for return to on-line mode button "History off" is used.

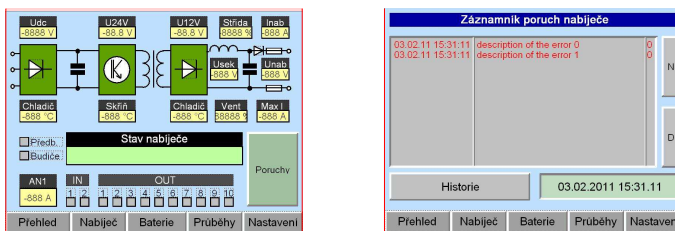

Komentář [PN2]:

Komentář [PN3]:

Battery

Actual status of battery is shown, in text description and as a measured value of battery voltage. By pressing "Monitor" button, the recorder of battery status is invoked. The recorder saves all non standard and error states of battery.

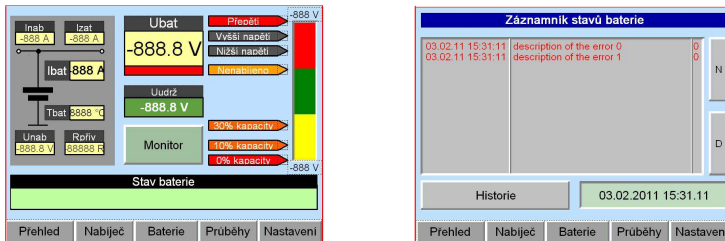

Komentář [PN4]:

Komentář [PN5]:

Charts

In this menu the output current, output voltage and battery voltage is shown. In charts the buttons „zoom+“ and „zoom-“ are available for movements in time-axis.

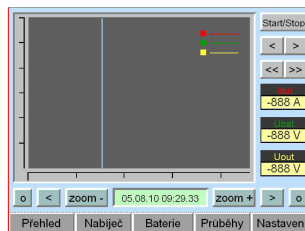

Komentář [PN6]:

Settings

During all service life of the charger there is no need to test charger parameters. For testing of its functionality or for re-set the parameters contact the manufacturer.

 Settings mode is used for setting inner values necessary for unit correct operation. It is strictly forbidden to change inner parameters without consulting with the manufacturer.

Screen is used for function setting of individual inputs and outputs and for setting of other operation parameters.

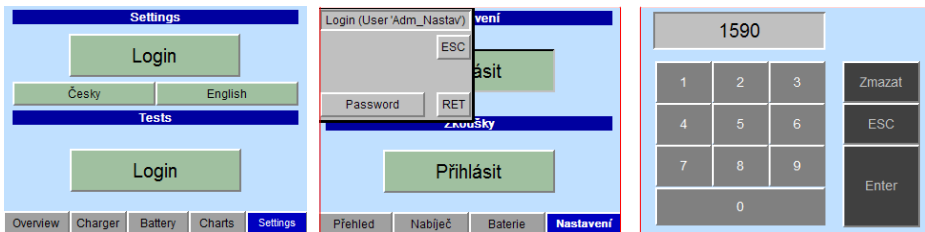

Komentář [PN7]:

Komentář [PN8]:

Password is necessary for entering – 1590. Press the button „Password“ for enter, insert the password and confirm by pressing „Enter“ and „RET“. For return without password insert press the button “ESC”. Last insert number can be deleting by pressing “Clear”.

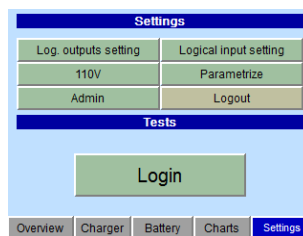

In menu “Logical outputs settings” the concrete function for each output can be set. For individual output different function can be used or the function can be negates. Also the actual status of each output is shown.

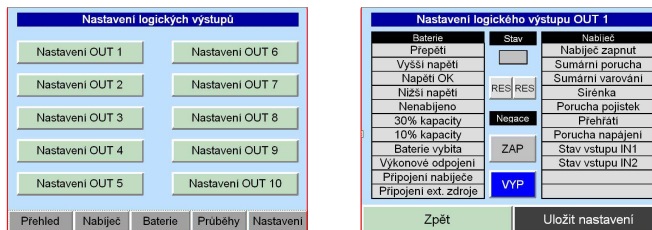

Komentář [PN9]:

Komentář [PN10]:

In menu “Logical inputs settings” the concrete function for each input can be set. For individual input only one function can be used.

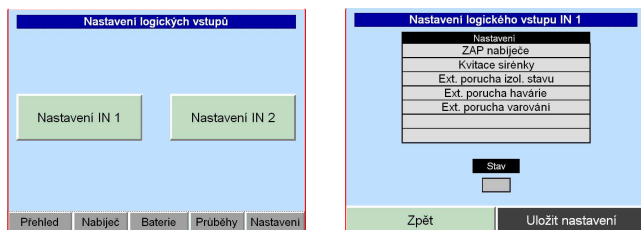

Komentář [PN11]:

Komentář [PN12]:

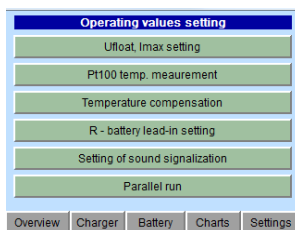

Wrong settings of charger parameters Ufloat or of maximal output current can cause battery harm or destruction. Settings of these parameters can perform only manufacturer.

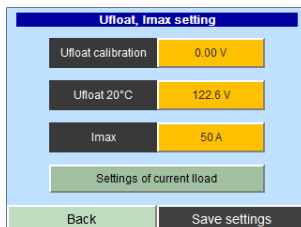

Parameterization menu provide enter to individual charger parameters. This possibility is left only for the manufacturer.



Komentář [PN13]:

The charger allows two-wire connection of Pt100. For accurate measurement the Pt100 can be calibrated and resistance of lead-in wiring can be set.

Komentář [PN14]:

There is a possibility for regime „Temperature compensation“ with using temperature sensor. The compensation in $\mu\text{V}/(^{\circ}\text{C}$ and cell) is shown in manual for batteries.



Wrong settings of temperature compensation can cause shortening if batteries lifetime.

Komentář [PN15]:

In case of long battery connection wiring is appropriate to compensate voltage decrease.

In regime of wiring resistance compensation is necessary to disconnect the battery, connect battery lead-in wiring, the charger perform resistance measurement. Measured value is saved to charger memory.

Komentář [PN16]:

The charger allows multiple language settings.

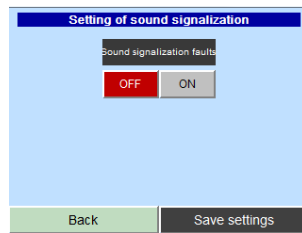

Sound signalization can be turned off.



Service settings serve only for manufacturer. Any manipulation is strictly forbidden.

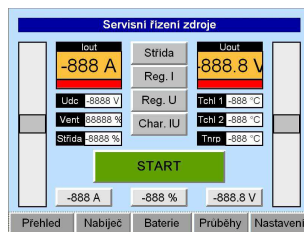

Tests regime serves to service settings. It is not recommended to test these elements or to change their values. Manipulation can cause harm or destruction of the charger or batteries or another connected device.

In Test regime individual components of charger can be controlled.

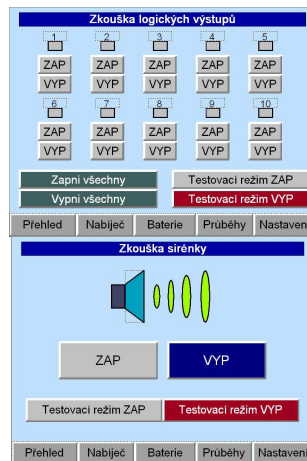
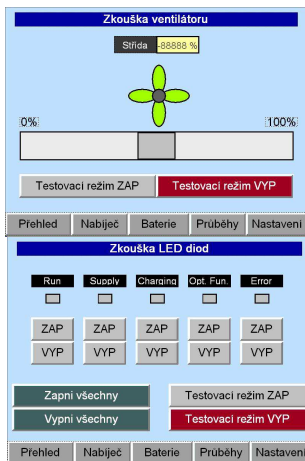

Error summary

Errors are announced on unit screen and by acoustic siren.

Parallel operation

Actually conn. chargers

Charger 1	Ichar: 888 A	<input type="checkbox"/> Master
Charger 2	Ichar: 888 A	<input type="checkbox"/> Master
Charger 3	Ichar: 888 A	<input type="checkbox"/> Master

Connect charger: 888 Icharg. total: 888 Icharg. avg: 888.7

Overview Chargers Battery Charts Settings

Operating values setting

- Ufloat, I_{max} setting
- Pt100 temp. measurement
- Temperature compensation
- R - battery lead-in setting
- Setting of sound signalization
- Parallel run

Overview Charger Battery Charts Settings

Setting of parallel run

Permit of parallel run
OFF ON

Address of rack: 1
Address of each charger must be unique.

Actual correction U_{out}: 0.0 V

Back Save settings

Maintenance

The device does not need any regular maintenance. The regular maintenance according to valid norms ČSN-EN – electro technical devices has to perform. This maintenance consists of visual control of the device, cleaning the device (best is via vacuum cleaner) and of control of proper tighten of screw joints.

This maintenance has to be performed in terms according to status of surroundings, but maximum 6 months duration.

Service and service assistance

In case of queries or problems with the device contact the producer:

PEG spol. s r.o., Baarova 49, 140 00 Prague 4, Czech Republic

Plant Kolbenova 922/5a, 190 00 Prague 9

www.peg.cz

peg@peg.cz

Tel: 281 087 521, fax: 281 087 522

GSM O₂: 724 366 435, T-mob: 731 118 119

Please, let us know about these details:

- Serial number of charger
- Date of first failure
- Failure description

Guarantee terms

Guarantee for material failure, construction failure and treatment and machining failure is provided for the devices, duration 24 months. The guarantee could be prolonged only via contract.

Producer is not responsible for any damage caused by wrong mounting; wrong operating conditions, settings change or any other conditions which are not in accordance with documentation. Producer is not responsible for consequences of wrong usage.

Producer of charger reserves the right to change technical data specification and details without former notice.